



AYUNTAMIENTO DE
LUVIANOS
2025-2027



FUERZA
JUVENTUD
Y TRABAJO

Catálogo de Subsidios





**AYUNTAMIENTO DE
LUVIANOS**
2025-2027



**FUERZA
JUVENTUD
Y TRABAJO**

CALENTADOR SOLAR



- 1.-ESTRUCTURA DE ACERO INOXIDABLE
- 2.- 5 AÑOS DE GARANTIA
- 3.- CALIBRE DE TERMOTANQUE ES 0.4 MM

CALENTADOR SOLAR DE 8 TUBOS \$2,700
CALENTADOR SOLAR DE 10 TUBOS \$2,900
CALENTADOR SOLAR DE 12 TUBOS \$3,200
CALENTADOR SOLAR DE 15 TUBOS \$3,600
CALENTADOR SOLAR DE 20 TUBOS \$4,500





TINACO CISTERPLAS DE 1,200 LTS



- 1.-TIENE UN DIAMETRO DE 1.07 METROS
- 2.- TIENE UNA ALTURA DE 1.40 METROS
- 3.- TIENE UN PESO EN KG DE 20 KILOGRAMOS



- INCLUYE LO SIGUIENTE :
- TAPA ROSCADA DE 17 PULGADAS
 - MULTICONECTOR CON LLAVE DE COMPUERTA
 - FLOTADOR
 - VALVULA DE ½ ,
 - JARO DE AIRE
 - BRIDA REFORZADA





AYUNTAMIENTO DE
LUVIANOS
2025-2027



FUERZA
JUVENTUD
Y TRABAJO

TINACO CISTERPLAS DE 5,000 LTS



- 1.-TIENE UN DIAMETRO DE 2 METROS
- 2.- TIENE UNA ALTURA DE 1.53 METROS
- 3.-. TIENE UN PESO EN KG DE 80 KILOGRAMOS

INCLUYE LO SIGUIENTE :

- TAPA ROSCADA DE 17 PULGADAS
- MULTICONECTOR CON LLAVE DE COMPUERTA





TINACO CISTERPLAS DE 10,000 LTS



- 1.-TIENE UN DIAMETRO DE 2.40 METROS
- 2.-. TIENE UNA ALTURA DE 2.70 METROS
- 3.-. TIENE UN PESO EN KG DE 200 KILOGRAMOS

INCLUYE LO SIGUIENTE :

- TAPA ROSCADA DE 17 PULGADAS
- MULTICONECTOR CON LLAVE DE COMPUERTA

TINACOS Y CISTERNAS DE 200 LITROS A 10,000 LITROS:

250 LTS	\$800
1200 LTS	\$1,650
1300 LTS	\$1,850
2500 LTS	\$4,050
5000 LTS	\$10,000
10000 LTS	\$20,500





COLCHONES EDIMAR



TAMAÑOS	DIMENCIONES	RESORTES
INDIVIDUAL	1.00 X 1.90 M	324
MATRIMONIAL	1.36 X 1.90 M	432
KING SIZE	2.00 X 1.90 M	648



Precio:

INDIVIDUAL: \$2,300

MATRIMONIAL: \$2,500

KING SIZE: \$3,300

- 1.- Forro acolchonado **multicapa**.
- 2.- Espuma ecologica que aporta **suavidad y confort**.
- 3.- Celdas abiertas, Air Flow, que brinda un **mayor soporte**.
- 4.- Espuma virgen, que **brinda firmeza**.
- 5.- Aislante para proteger la espuma.
- 6.- Resortes blonicos con alto contenido de carbono para **mayor durabilidad**.
- 7.- Aislante para proteger la espuma
- 8.- Espuma virgen, que **brinda firmeza**.
- 9.- Celdas abiertas, Air Flow, que brinda un **mayor soporte**.
- 10.- Forro acolchonado mutlticapa con tela de algodón **antibacterial y antialergica**.

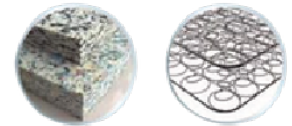



**AYUNTAMIENTO DE
LUVIANOS**
— 2025-2027 —



**FUERZA
JUVENTUD
Y TRABAJO**

BASE PARA COLCHON

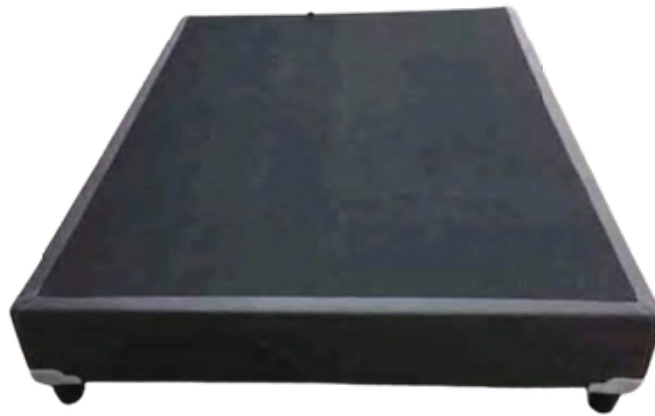

Características:

Material - Madera

	Matrimonial	Individual
Largo, Ancho, Altura	190cm x 132cm x 32cm	190cm x 100cm x 32cm

Tapiz de Tacto Piel y una pequeña plancha de triplay y espuma de poliuretano

Precio:
INDIVIDUAL: \$1,750

MATRIMONIAL: \$1,900

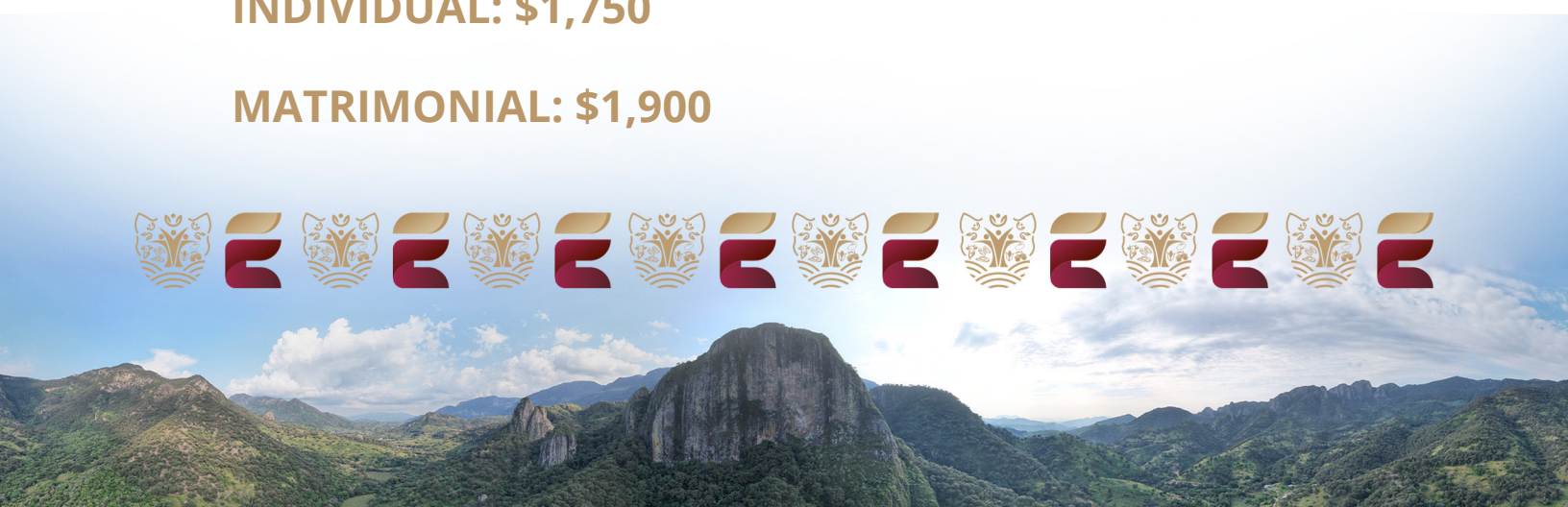



**AYUNTAMIENTO DE
LUVIANOS**
— 2025-2027 —



**FUERZA
JUVENTUD
Y TRABAJO**

LAMINAS CALIBRE #32

80CM X 3 MTS

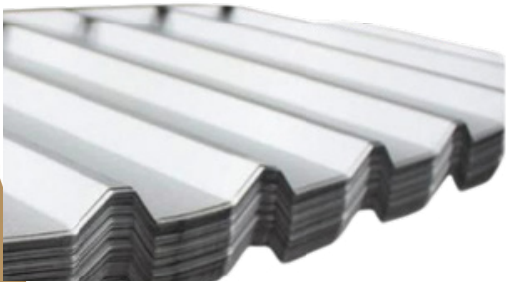

**LAMIA RECTAGULAR CON
REFUERZO**



Precio: \$2,800

Paquete de 10 piezas





AYUNTAMIENTO DE
LUVIANOS
2025-2027



FUERZA
JUV **ENTUD**
Y **TRABAJO**

PLASTITEJA

3 MTS X 1.25 MTS

LAMINA RECTAGULAR CON
REFUERZO

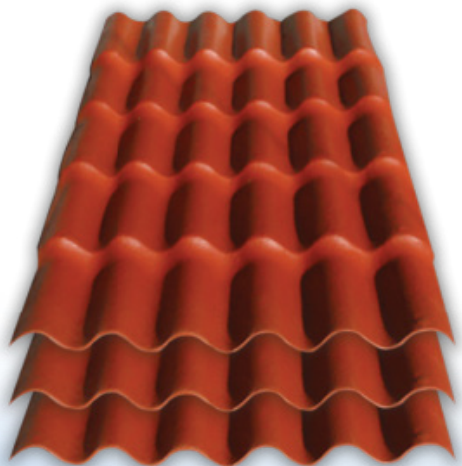
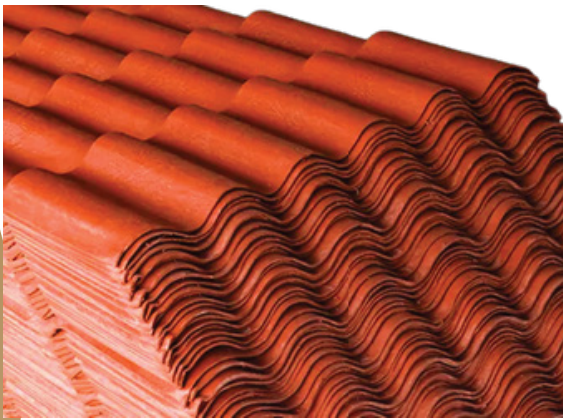

Por pieza

Precio: \$540





AYUNTAMIENTO DE
LUVIANOS
2025-2027



FUERZA
JUV **ENTUD**
Y **TRABAJO**

GALVATEJA



3 MTS X 1.25 MTS

LAMIA RECTAGULAR CON REFUERZO

Calibre-26

Por pieza

Precio: \$820





KIT DE FREGADERO

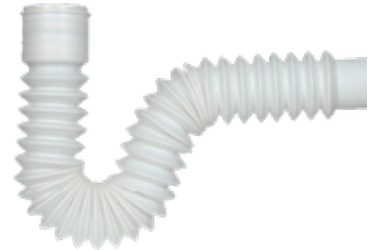

- INCLUYE**
- FREGADERO 100X50**
 - 2 MANGUERA PARA FREGADERO**
 - 1 CESPO PARA FREGADERO**
 - 1 MEZCLADORA PARA FREGADERO**
 - 2 LLAVE ANGULAR**
 - 1 CONTRACANASTA**

Precio: \$1,400





AYUNTAMIENTO DE
LUVIANOS
2025-2027



FUERZA
JUVEN
TUD
Y TRABAJO

KIT DE FREGADERO DOBLE

INCLUYE

FREGADERO 100X50

2 MANGUERA PARA FREGADERO

1 CESPO PARA FREGADERO

1 MEZCLADORA PARA FREGADERO

2 LLAVE ANGULAR

1 CONTRACANASTA



Precio: \$1,650





JUEGO DE BAÑO

Características Generales

- Sanitario de dos piezas.
- Trampa expuesta de 2".
- Bajo consumo de agua, descarga menos de 5 litros.
- Certificado por la CONAGUA como producto de grado ecologico.
- Diseño ergonomico que va a la vanguardia del diseño ceramico.
- Ceramica vitrificada de alta temperatura (1,225C).
- Diseño de trampa silencioso y eficiente.
- Presion de trabajo minima recomendada 0.25KG/cm2.



**COLOR DISPONIBLE
EN BLANCO**

**Pedestal para
lavabo
SE VENDE POR
SEPARADO**

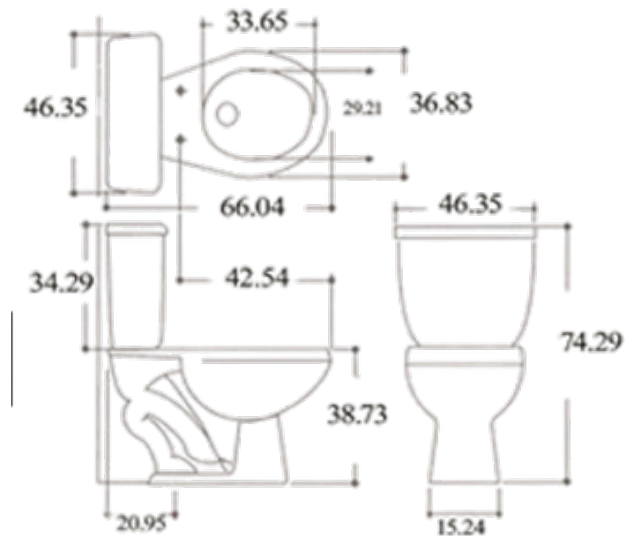

Dimenciones en cm

Precio: \$1,800





KIT JUEGO DE BAÑO

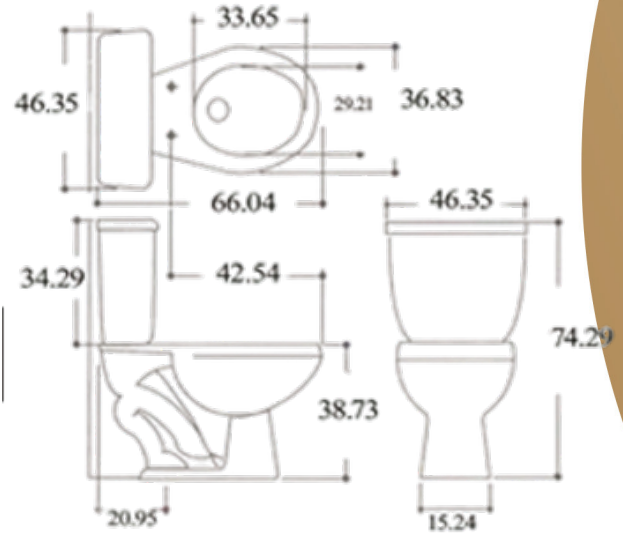

Dimensiones en cm

COLOR DISPONIBLE EN BLANCO

Precio: \$2,600

incluye:

- 1-3 mangueras flexibles
- 2-cepel
- 3-chupon
- 4-mezcladora
- 5-tapa de asiento
- 6-anclas
- 7-3 llaves de engüerales
- 8-tornillos

Características Generales

- Sanitario de dos piezas.
- Trampa expuesta de 2".
- Bajo consumo de agua, descarga menos de 5 litros.
- Certificado por la CONAGUA como producto de grado ecologico.
- Diseño ergonomico que va a la vanguardia del diseño ceramico.
- Ceramica vitrificada de alta temperatura (1,225C).
- Diseño de trampa silencioso y eficiente.
- Presion de trabajo minima recomendada 0.25KG/cm2.





JUEGO DE BAÑO ONE PIECE



**GRAN CAPACIDAD DE
DESCARGA.**

**TAMAÑO IDEAL PARA SU
COMODIDAD.**

**CAPACIDAD: DESCARGA 700
GRAMOS C/N 6,0 L
(ECOLOGICO)**

**DESIGNACION DUAL DE:
6,0 L / 4,2 L**



Precio: \$2,850





AYUNTAMIENTO DE
LUVIANOS
— 2025-2027 —



FUERZA
JUVENTUD
Y TRABAJO

JUEGO DE HERRAMIENTAS



INCLUYE

- *CARRETILLA**
- *PALA CUADRADA**
- *MACHETE**
- *PALA REDONDA**
- *PICO**

Precio: \$1,900





**AYUNTAMIENTO DE
LUVIANOS**
2025-2027



**FUERZA
JUVENTUD
Y TRABAJO**

JUEGO DE HERRAMIENTAS DE JARDINERIA

INCLUYE
***CARRETILLA**
***PALA**
***MACHETE**
***AZADON**
***ESCOBA**
JARDINERA



Precio: \$1,600





AYUNTAMIENTO DE
LUVIANOS
— 2025-2027 —



FUERZA
JUVENTUD
Y TRABAJO

JUEGO DE HERRAMIENTAS



PAQUETE DE HERRAMIENTAS CON BOMBA: \$2,200





LAMPARAS SOLARES Y FOCOS

REFLECTOR SOLAR 100W y 200W



Reflector Solar

Mando a distancia.

Proteccion contra rayos y lluvia.

Tipo de lampara: Led.

Material: Hierro.

3 etapas de iluminacion: 3/ 5/ 8 hrs.

Precio: \$1,000

Lampara Solar

Sensor de movimiento.

Mando a distancia.

Resistencia IP66 a la lluvia y polvo

Carga solar: 4-6 hrs.

Autonomia de bateria: + 18 hrs.

Color de luz: Blanco frio 6500 k



Precio: \$1,150





ACCESORIOS DE CASA

Cable de calibre #12 de 100 m Precio: \$650



Aislamiento: cubierto con PVC u otros aislantes como THHN o THW que soportan temperaturas nominales de hasta 90°C

Material: Predominantemente cobre electrolítico con alta pureza (aprox. 99.995%), que le otorga buena conductividad y resistencia

aspersora manual de 15 L



Precio: \$750





ACCESORIOS DE CASA

MOTOSIERRA

Precio: \$2,200



Equipada con un potente motor de dos tiempos, esta herramienta, es ideal para trabajos de jardinería y mantenimiento de áreas verdes

Ideal para cortes y limpieza de terrenos y áreas públicas.

Desbrozadora



Precio: \$2,000





ACCESORIOS DE CASA

Base para tinaco

Para tinaco de hasta 1300 litros

Altura 1.07 m

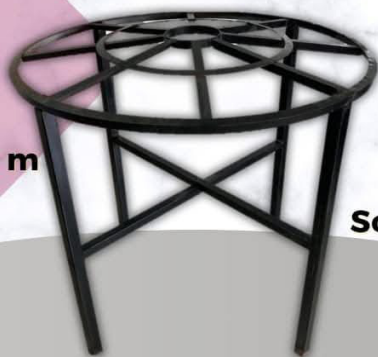

Soporta 1300



Precio: \$1,700

bomba de agua de 1/2 hp



Potencia	1/2 Hp
Voltaje	127 V
Flujo Maximo	35 L/min.
Altura Maxima	25 M
Succion Maxima	8 M
Embobinado de Motor	Cobre

Precio: \$450





AYUNTAMIENTO DE
LUVIANOS
2025-2027



FUERZA
JUVENTUD
Y TRABAJO

ACCESORIOS DE CASA

PAQUETE TINACO DE 1200
LITROS REFORZADO +
BOMBA DE MEDIO CABALLO



Precio: \$2,000





ACCESORIOS DE CASA

Tanque de gas de 20 kg



Válvula de seguridad
contra sobre-presión



Prueba de fugas
hidrostáticamente a presión



Acabado exterior pintura
electrostática en polvo



Fácil transportación



89.8 cm

30.1 cm

Precio:

9 KILOS: \$1,100

20 KILOS: \$1,700





ACCESORIOS DE CASA

Tanque de gas de 30 kg



- | | |
|--|---|
|  CUERPO EN ACERO |  FÁCIL TRANSPORTACIÓN |
|  VALVULA INTELIGENTE DE SEGURIDAD |  PRUEBA DE FUGAS HIDROSTATICAS |
|  PINTURA ELECTROSTÁTICA |  FÁCIL DE INSTALAR |

Precio: \$2,200





**AYUNTAMIENTO DE
LUVIANOS**
2025-2027



**FUERZA
JUVENTUD
Y TRABAJO**

ACCESORIOS DE CASA

Pintura de casa de 19 litros marca sayer

5 años de durabilidad



color disponible en blanco

Precio: \$900



Impermeabilizante de casa de 19 litros marca sayer

5 años de durabilidad

Precio: \$950





ACCESORIOS DE CASA

Parrilla Estante



Precio: \$2,600

PARRILLA QUEMADOR, COMAL Y FREIDORA



Precio: \$3,000





ACCESORIOS DE CASA

ESTUFAS



ESTUFA MARCA MIDEA

- 4 quemadores
- Cubierta de acero inoxidable
- Ventana panorámica

Precio: \$4,500

ESTUFA MARCA ACROS

- 6 quemadores
- Puerta panoramica semi ahumada
- Horno

Precio: \$6,000





ACCESORIOS DE CASA: RECÁMARAS



CABECERA, BUROS
Y TOCADOR COLOR
GRIS

Precio: \$5,500



CABECERA,
BUROS, ESPEJO Y
CAJONERA COLOR
CAFÉ

Precio: \$6,200





AYUNTAMIENTO DE
LUVIANOS
— 2025-2027 —



FUERZA
JUV **ENTUD**
Y **TRABAJO**

ACCESORIOS DE CASA: RECÁMARAS

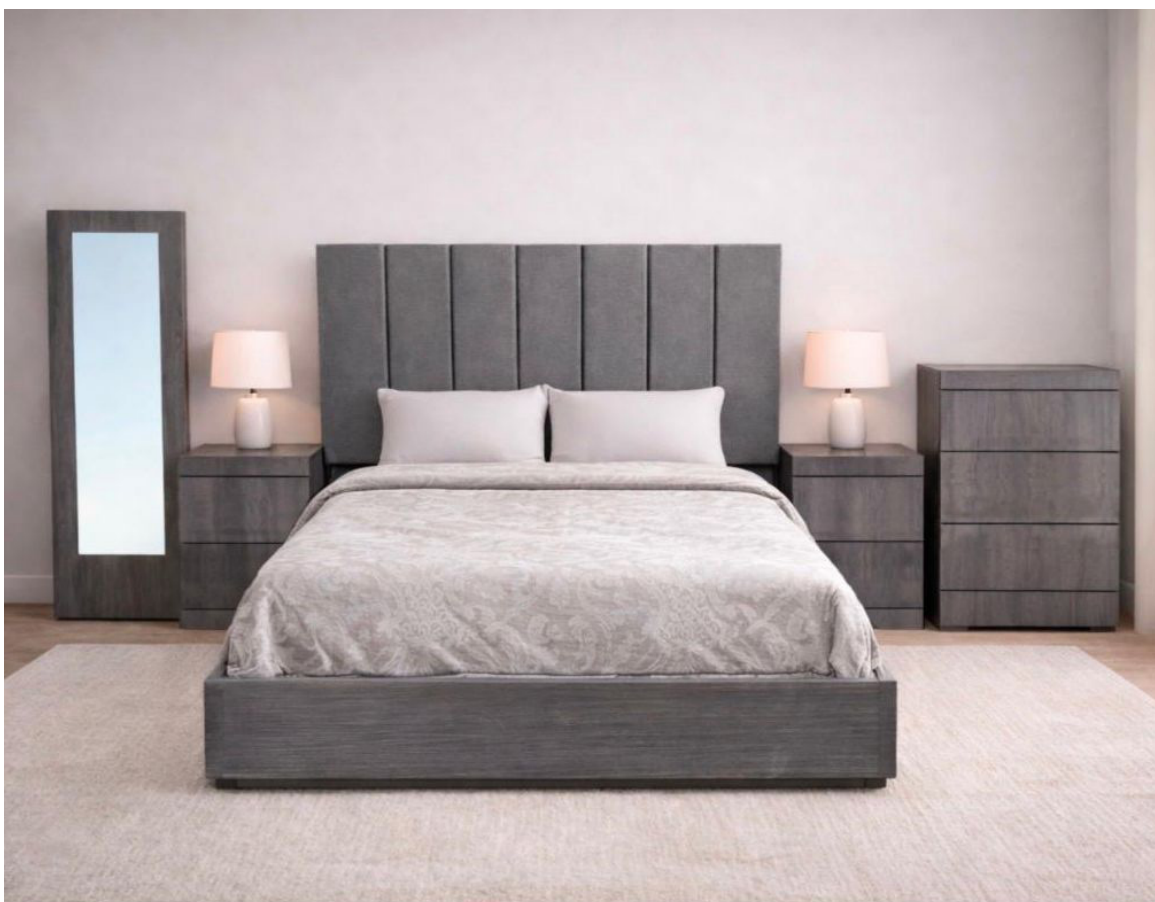

RECÁMARA COMPLETA (COLCHÓN, BASE,
CABECERA, BUROS Y TOCADOR)

Precio: \$8,000





ACCESORIOS DE CASA



SILLON 3 PIEZAS
COLOR GRIS

Precio: \$5,000



LAVADORA DOBLE
TINA 12 KILOS

Precio: \$3,500



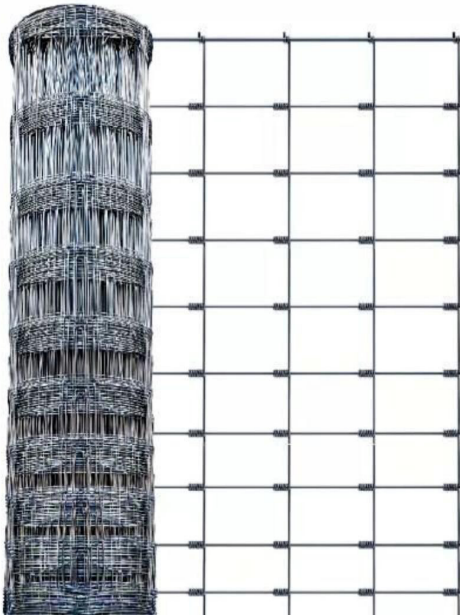

**TELA BORREGUERA 1.70
DE ALTURA, 50 MTS DE
LARGO ROLLO**

Precio: \$1,600



**MALLA CICLÓNICA
ALTURA 2MTS X 20 MTS
DE LARGO CALIBRE 12.5**

Precio: \$2,200





**AYUNTAMIENTO DE
LUVIANOS**
2025-2027



**FUERZA
JUVENTUD
Y TRABAJO**

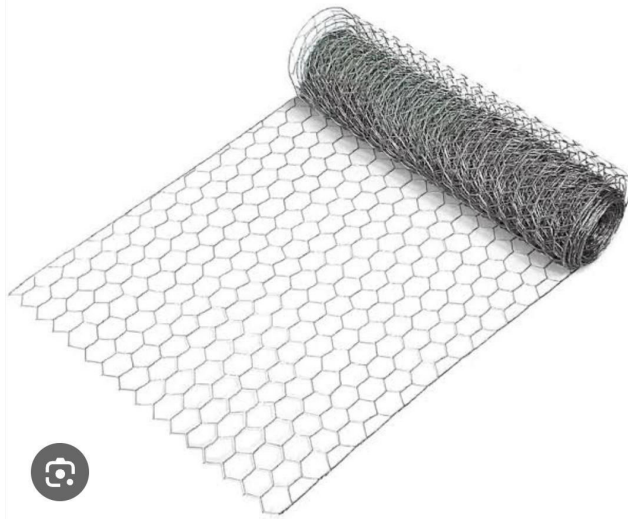

**TELA GALLINERA DE
1 MTS DE ALTURA X 45
MTS DE LARGO**

Precio: \$950



**ALAMBRE DE PÚAS 30
KILOS CALIBRE 12.5
EQUIVALENTE A 300
MTS**

Precio: \$1,200





AYUNTAMIENTO DE LUVIANOS
2025-2027



FUERZA JUVEN TUD Y TRABAJO



CARPAS TOLDO

3X3 MTS

Precio: \$850

Rotomartillo/destornillador 1/2", 550W, PRETUL

TALADRO



Precio: \$700





**AYUNTAMIENTO DE
LUVIANOS**
— 2025-2027 —



**FUERZA
JUVENTUD
Y TRABAJO**

**Para más información acudir a la
oficina de la Dirección del Bienestar
con la Lic. Jazmin Benítez Flores.**

**La oficina está ubicada en el Centro
Administrativo, calle Picardo Pagaza,
esquina con Calle Bicentenario, a un
costado del Mercado Municipal.**

